

Sanitary Grade Electromagnetic Flow Meter Model : SG - Sroat



Features :

- Full Stainless Steel Body.
- End Connection in Union Coupling/tri-clover clamp
- Sizes Available from 1" to 4".
- Highly Accurate and extremely Linear.
- Isolated 4-20 mA output Proportional to flow rate.
- Option of Pulse Output available.

Description :

The Series SG-Sroat of Electromagnetic Flow Meters is specifically designed for measurement of food liquids like milk, cream, juices of various fruits, pharma liquids etc. It is available with integral or remote version of transmitter. The transmitter can have built-in or remote totalizer display. Suitable end connections of SMS Union or DIN Union or Tri-clover Clamp is given as per customer's requirements. Special models are available for mounting on Milk Tankers.

* Technical Specifications :

Meter Size	: 1" to 4"
Pressure	: 40 Bar max.
Media Temperature	: 150°C max.
Ambient Temperature range	: 4 to 50°C
Material	: Pipe : SS304 Liner : PTFE Food Grade Electrodes : SS316L Coil Housing : SS304/SS316 End Connections : SS304/SS316
Type of Transmitter	: Sroat 1000A
Min. Media conductivity	: 5 micro-siemens per cm.
Output	: 1) 4 to 20 mA proportional to flow Rate, isolated from input, body and power supply (Standard). 2) Pulse Output, open collector type, proportional to totalizing rate(Optional).
Local Display(Optional)	: a) Flow Rate, 3½ digit LCD. b) Total Quantity, 8 Digit LCD.
Accuracy	: 0.5% of reading from 100% to 10% flow rate.
Flow Velocity Range	: 0.1 m/s to 10m/s.(Higher velocities can be catered on request).
Power Supply	: 1) 110Vac/ 230Vac, 50/60 Hz.(Standard) 2) 24 Vdc/12Vdc. (Optional)
Power Rating	: 10VA Max.
Ingress Protection	: IP68 for Primary Flow Sensor, IP65 for flow Transmitter.



Flow Rate Table at v = 1m/s

SIZE	m ³ /Hr.	LPM	LPS
25	1.767	29.452	0.490
32	2.895	48.254	0.804
38	4.523	75.398	1.256
51	7.068	117.809	1.963
63.5	11.945	199.098	3.318
76.1	18.095	301.592	5.026
101.6	28.274	471.238	7.853
104	28.274	471.238	7.853



Table for Meter Dimensions(mm)

Meter Size	A	B	C	D
25	80	200	135	25 SMS
32	100	200	140	32 SMS
38	100	200	140	38 SMS
51	105	200	210	51 SMS
63.5	105	200	215	63.5SMS
76.1	105	200	220	76.1SMS
101.6	130	250	305	101.6SMS
104	130	250	305	104 SMS

Note : The dimensions are with terminal box.

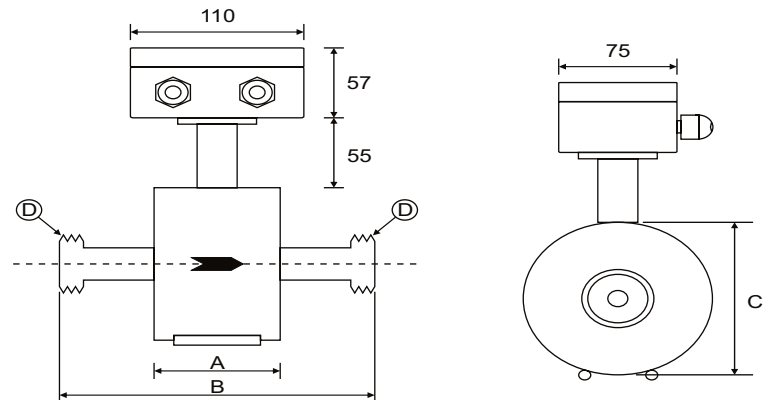

Ordering Information :

Size of Flow Meter	
25 mm	63.5 mm
32 mm	76.1 mm
38 mm	101.6 mm
51 mm	104 mm

End Connection	
TC	Tri-Clover Clamp
SU	SMS Union
DU	DIN Union

MOC of Body and End Connection	
SS304	
SS316	
SS316L	

Flow Transmitter	
FT-01	Integral
FT-02	Remote

Power Supply	
01	110Vac/50 or 60 Hz
02	230Vac/50 or 60 HZ
03	24Vdc
04	12Vdc

SG-Sroat Size 32 - SU - SS316 - FT02 - 02 **Sample Order Code**

* Due to continuous development specifications are subject to change without prior notice.



Unit No. 35/36/41, Om Anand Industrial Estate,
M. S. Road, Raghunath Nagar, Thane(W) - 400601.
Tele : 022 - 2583 23 23, 022 - 25823708
Mobile : +91 9833504585 / 9022827363
Email : tansaindia@gmail.com / sales@tansa.co.in

www.tansa.co.in
www.rotameters.co.in
www.orificeplate.in
www.flowmetersindia.net